

# AUTOMOTIVE CURRENT TRANSDUCER

## HAH1BV S/09

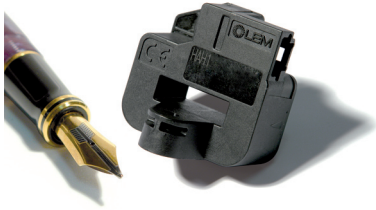

### Introduction

The HAH1BV family is for the electronic measurement of DC, AC or pulsed currents in high power automotive applications with galvanic isolation between the primary circuit (high power) and the secondary circuit (electronic circuit)

The HAH1BV family gives you the choice of having different current measuring ranges in the same housing (from  $\pm 200$  A up to  $\pm 900$  A).

### Features

- Open Loop transducer using the Hall effect
- Unipolar + 5 V DC power supply
- Primary current measuring range up to  $\pm 300$  A
- Maximum rms primary current limited by the busbar, the magnetic core or the ASIC temperature  $T^\circ < + 150^\circ\text{C}$
- Operating temperature range:  $- 40^\circ\text{C} < T^\circ < + 125^\circ\text{C}$
- Output voltage: full ratio-metric (in gain and offset)
- Compact design.

### Advantages

- Excellent accuracy
- Very good linearity
- Very low thermal offset drift
- Very low thermal gain drift
- Wide frequency bandwidth
- No insertion losses.

### Automotive applications

- Battery monitoring
- Starter Generators
- Inverters
- HEV application
- EV application.

### Principle of HAH1BV Family

The open loop transducers use an Hall effect integrated circuit.

The magnetic flux density  $B$ , contributing to the rise of the Hall voltage, is generated by the primary current  $I_p$  to be measured.

The current to be measured  $I_p$  is supplied by a current source i.e. battery or generator (Fig. 1).

Within the linear region of the hysteresis cycle,  $B$  is proportional to:

$$B (I_p) = \text{constant} (a) \times I_p$$

The Hall voltage is thus expressed by:

$$V_H = (R_H/d) \times l \times \text{constant} (a) \times I_p$$

Except for  $I_p$ , all terms of this equation are constant. Therefore:

$$V_H = \text{constant} (b) \times I_p$$

The measurement signal  $V_H$  amplified to supply the user output voltage or current.

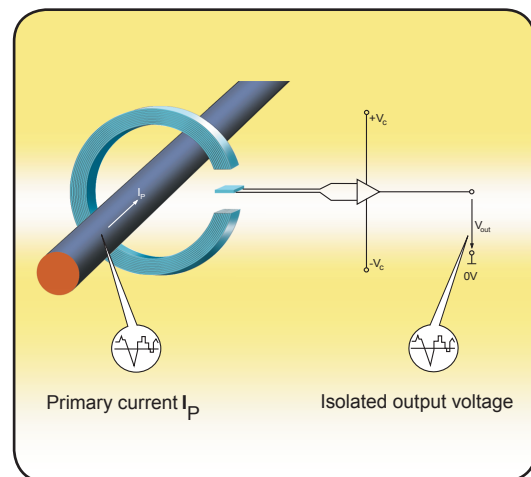

Fig. 1: Principle of the open loop transducer

## HAH1BV S/09

Dimensions HAH1BV family (in mm. 1mm = 0.0394 inch)

**MOUNTING RECOMMENDATION**  
(2 mounting options)

Use screw Ø4 mm  
Max recommended Torque 2.2 Nm (torque wrench recommended to avoid e  
Spring washers

It is recommended to use only one fixation point at the same time.

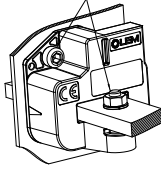

Current flow  
direction

Right view

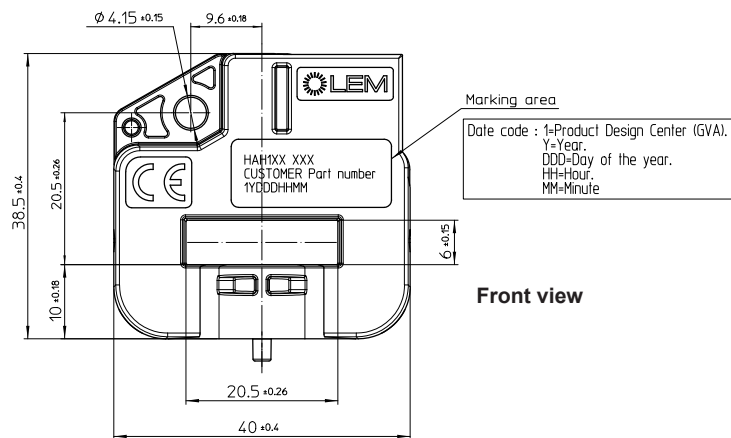
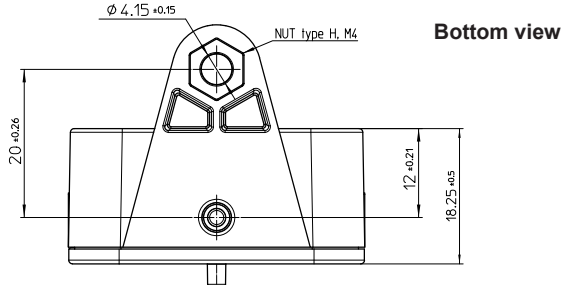
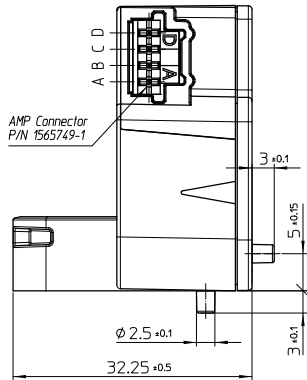

**Bill of materials**

- Plastic case PBT GF 30
- Magnetic core Iron silicon alloy
- Pins Brass tin plated
- Weight 39 g

**Remarks**

- $V_{OUT} > \frac{V_C}{2}$  when  $I_p$  flows in the direction of the arrow.

**System architecture**

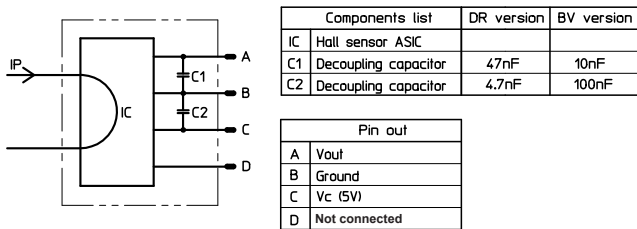

**System architecture (example)**

$R_L > 10\text{ k}\Omega$  optional resistor for signal line diagnostic

$V_{OUT}$	Diagnosis
Open circuit	$V_{IN} = V_C$
Short GND	$V_{IN} = 0V$

$C_L < 100\text{ nF}$  EMC protection

RC Low pass filter EMC protection (optional)

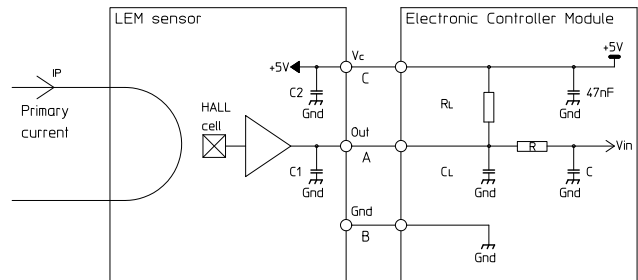

## HAH1BV S/09

### Absolute maximum ratings

	Symbol	Unit	Specification			Conditions
			Min	Typ	Max	
<b>Electrical Data</b>						
Max primary current peak	$I_{Pmax}$	A			1)	
Supply continuous over voltage	$V_C$	V			8.5	
Supply over voltage					14	1 min
Reverse voltage			-14			1 min @ $T_A = 25^\circ\text{C}$
Output over voltage (continuous)	$V_{OUT}$	V			8.5	
Output over voltage					14	1 min @ $T_A = 25^\circ\text{C}$
Continuous output current	$I_{OUT}$	mA	-10		10	
Output short-circuit duration	$t_c$	min			2	
Rms voltage for AC isolation test	$V_d$	kV			2	50 Hz, 1 min
Isolation resistance	$R_{IS}$	MΩ	500			500 V - ISO 16750-2
Electrostatic discharge voltage	$V_{ESD}$	kV			2	JESD22-A114-B
Ambient storage temperature	$T_S$	$^\circ\text{C}$	-40		125	

### Operating characteristics

	Symbol	Unit	Specification			Conditions
			Min	Typ	Max	
<b>Electrical Data</b>						
Primary current	$I_P$	A	-300		300	
Calibration current	$I_{CAL}$	A	-300		300	@ $T_A = 25^\circ\text{C}$
Supply voltage	$V_C$	V	4.5	5.00	5.25	
Output voltage	$V_{OUT}$	V	$V_{OUT} = (V_C/5) \times (2.5 + G \times I_P)$			@ $V_C$
Sensitivity <sup>2)</sup>	$G$	mV/A		6.67		@ $V_C = 5\text{ V}$
Current consumption	$I_C$	mA		7	10	@ $V_C = 5\text{ V}$ , $-40^\circ\text{C} < T_A < 125^\circ\text{C}$
Power up inrush current		mA				15
Load resistance	$R_L$	KΩ	10			
Output internal resistance	$R_{OUT}$	Ω			10	
Capacitive loading	$C_L$	nF	1		100	
Ambient operating temperature	$T_A$	$^\circ\text{C}$	-40		125	
Output drift versus power supply		%	-1	0.3	1	
<b>Performance Data</b>						
Sensitivity error	$\varepsilon_G$	%	-1.0	± 0.5	1.0	@ $T_A = 25^\circ\text{C}$ , @ $V_C = 5\text{ V}$
Electrical offset current	$I_{OE}$	A		± 0.75		@ $T_A = 25^\circ\text{C}$ , @ $V_C = 5\text{ V}$
Magnetic offset current	$I_{OM}$	A		± 0.6		@ $T_A = 25^\circ\text{C}$ , @ $V_C = 5\text{ V}$ after ± $I_P$
Globale offset current	$I_O$	A		± 1.35		@ $T_A = 25^\circ\text{C}$
			-2.7		2.7	
Average temperature coefficient of $V_{OE}$	$TCV_{OE\text{AV}}$	mV/ $^\circ\text{C}$	-0.06	± 0.02	0.06	@ $-40^\circ\text{C} < T_A < 125^\circ\text{C}$
Average temperature coefficient of $G$	$TCC_{G\text{AV}}$	%/ $^\circ\text{C}$	-0.04	± 0.02	0.04	@ $-40^\circ\text{C} < T_A < 125^\circ\text{C}$
Linearity error	$\varepsilon_L$	%	-1.0		1.0	of full range
Response time to 90 % of $I_{PN}$ step	$t_t$	ms			5	@ $di/dt = 100\text{ A}/\mu\text{s}$
Frequency bandwidth	<b>BW</b>	Hz	1880	2000		@ -3 dB
Output clamping min voltage	$V_{sz}$	V	0.24	0.25	0.26	@ $V_C = 5\text{ V}$
Output clamping max voltage	$V_{sz}$	V	4.74	4.75	4.76	@ $V_C = 5\text{ V}$
Output voltage noise peak peak	$V_{nd\text{pp}}$	mV	-		10	
Resolution		mV		2.5		@ $V_C = 5\text{ V}$
Power up time		ms		25	100	
Setting time after overload		ms			25	

- Notes:**
- 1) Busbar temperature must be below  $150^\circ\text{C}$ .
  - 2) The output voltage  $V_{OUT}$  is fully ratiometric. The offset and gain are dependent on the supply voltage  $V_C$  relative to the following formula

$$I_P = \left( V_{OUT} - \frac{V_C}{2} \right) \times \frac{1}{G} \times \frac{5}{V_C} \quad \text{with } G \text{ in (V/A)}$$

## HAH1BV S/09

HAH1BV S/09 Gain Error (%)

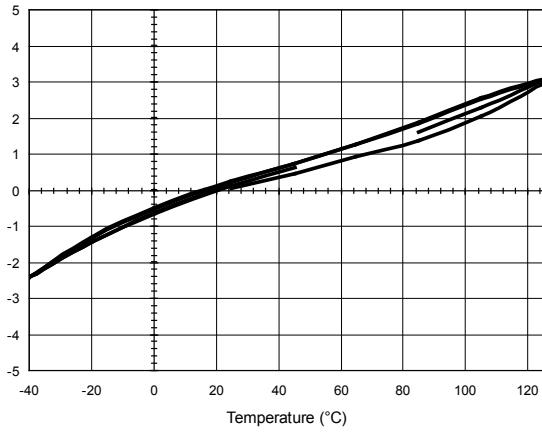

HAH1BV S/09 Electrical offset Error (A)

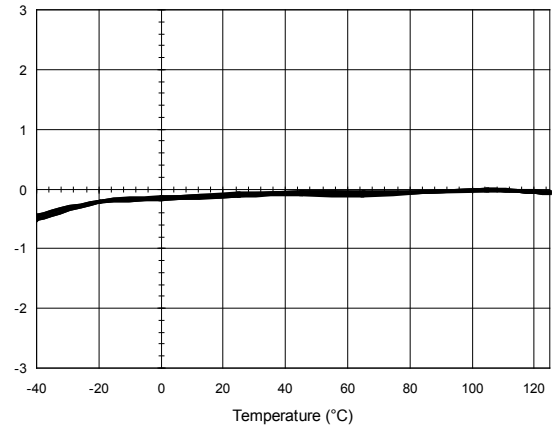

## HAH1BV S/09

### PERFORMANCES PARAMETERS DEFINITIONS

#### Output noise voltage:

The output voltage noise is the result of the noise floor of the Hall elements and the linear  $I_c$  amplifier gain.

#### Magnetic offset:

The magnetic offset is the consequence of an over-current on the primary side. It's defined after an excursion of  $I_{p\max}$ .

#### Linearity:

The maximum positive or negative discrepancy with a reference straight line  $V_{OUT} = f(I_p)$ .

Unit: linearity (%) expressed with full scale of  $I_{p\max}$ .

Linearity is measured on cycle +  $I_p$ , 0, -  $I_p$ , 0, +  $I_p$  without magnetic offset (average values used)

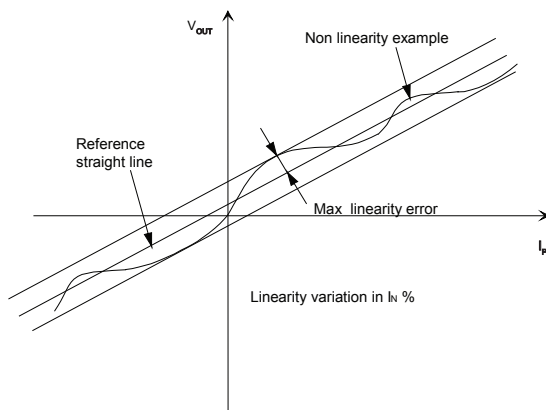

#### Response time (delay time) $t_r$ :

The time between the primary current signal and the output signal reach at 90 % of its final value

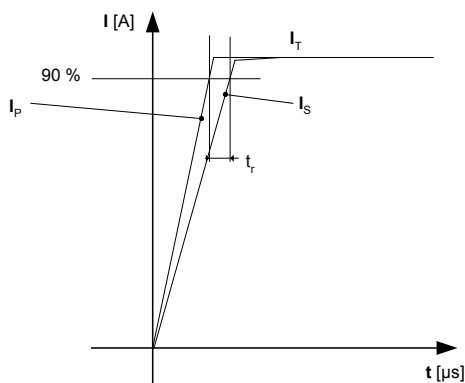

#### Typical:

Theoretical value or usual accuracy recorded during the production.

#### Sensitivity:

The Transducer's sensitivity  $G$  is the slope of the straight line

$V_{out} = f(I_p)$ , it must establish the relation:

$$V_{out}(I_p) = V_c/5 (G \times I_p + 2.5) (*)$$

(\*) For all symetrics transducers.

#### Offset with temperature:

The error of the offset in the operating temperature is the variation of the offset in the temperature considered with the initial offset at 25°C.

The offset variation  $I_{OT}$  is a maximum variation the offset in the temperature range:

$$I_{OT} = I_{OE\max} - I_{OE\min}$$

The Offset drift  $TCI_{OEAV}$  is the  $I_{OT}$  value divided by the temperature range.

#### Sensitivity with temperature:

The error of the sensitivity in the operating temperature is the relative variation of sensitivity with the temperature considered with the initial offset at 25°C.

The sensitivity variation  $G_T$  is the maximum variation (in ppm or %) of the sensitivity in the temperature range:

$$G_T = (Sensitivity\ max - Sensitivity\ min) / Sensitivity\ at\ 25^\circ C.$$

The sensitivity drift  $TCG_{AV}$  is the  $G_T$  value divided by the temperature range.

#### Offset voltage @ $I_p = 0$ A:

Is the output voltage when the primary current is null. The ideal value of  $V_o$  is  $V_c/2$  at  $V_c = 5$  V. So, the difference of  $V_o - V_c/2$  is called the total offset voltage error. This offset error can be attributed to the electrical offset (due to the resolution of the ASIC quiescent voltage trimming), the magnetic offset, the thermal drift and the thermal hysteresis.

#### Environmental test specifications

Name	Standard	Conditions
Damp heat, steady state	JESD22-A101	85°C - 85°C / 1000h
Isolation resistance	ISO 16750-2 § 4.10	500 V/1min
Temperature humidity cycle test	ISO 16750-4	-10 + 85°C 10 days
Isolation test	IEC 60664-1	2 kV/50 Hz/1min
<b>Mechanical tests</b>		
Vibration test (random)	IEC 60068-2-64 ISO 16750-3 & 4.1.6.1.6	20 ... 2000 Hz Random rms (11g rms) 8h/axis
Terminal strength test	According to LEM	
Thermal shocks	IEC 60068-214 Na	-40 + 125°C 300 cycles
Free fall	ISO 16750-3 § 4.3	1m concrete ground
<b>EMC Test</b>		
Radiated electromagnetic immunity	Directive 2004/104/CE ISO 11452-2	30 V/m 20-2000 MHz
Bulk current injection immunity	Directive 2004/104/CE ISO 11452-4	1-400 MHz
Radiated radio frequency electromagnetic field immunity	IEC 61000-4-3	80000 MHz-10V/m
Electrostatic discharge immunity test	IEC 61000-4-2	Air discharge=2 kV